

HORIBA

Process & Environmental

Air Pollution Monitor AP-370 Series

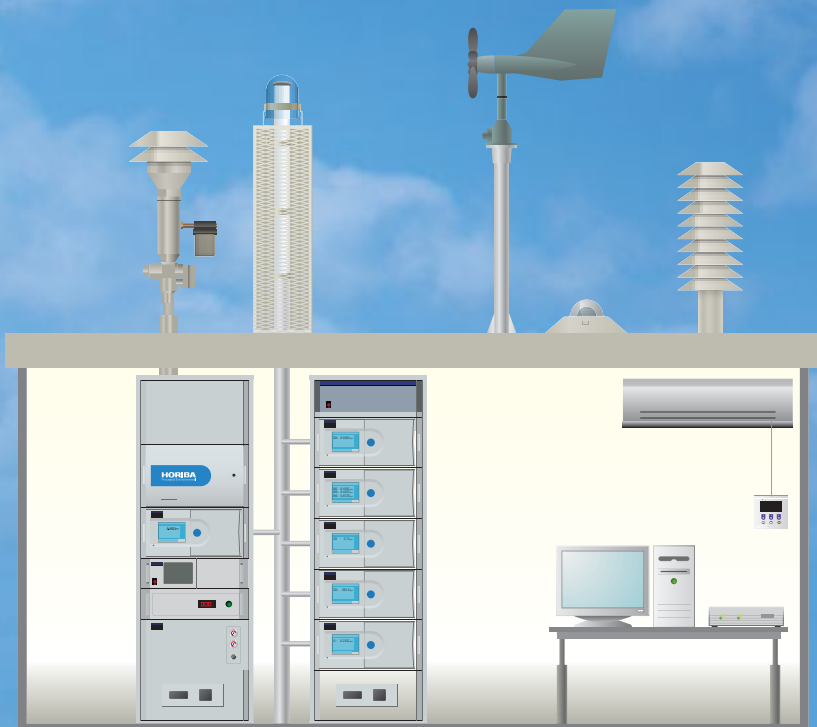

AQMS

Air Quality Monitoring System

Air Pollution Monitor

AP-370 Series

Precise, Reliable, Easy maintainance

HORIBA has more than 50 years experience providing ambient monitoring solutions, recognized around the world. HORIBA has supplied over 15,000 units with the major share in many regions. The monitoring station is tailor-made according to the customer's request. HORIBA can provide several types of stations, cabinets, calibration equipment and more to meet your challenging monitoring requirements.

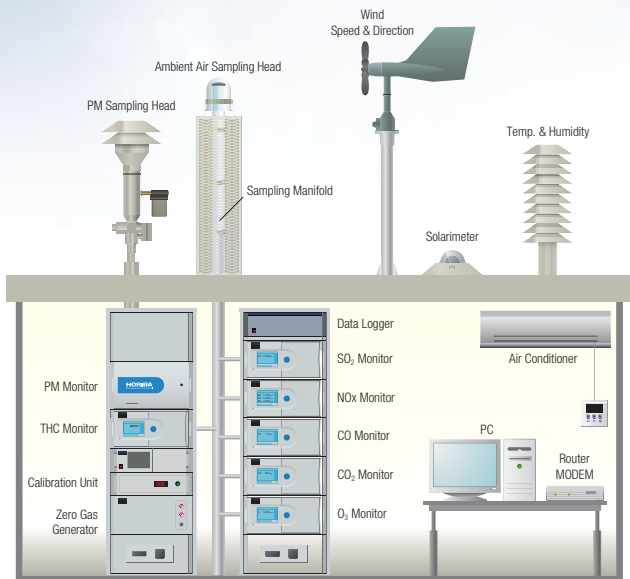

AQMS Air Quality Monitoring System



Gas and Particulate Monitor

| | | |
|-----------------------|---------------|-----|
| CO | APMA-370 | P.2 |
| CO₂ | APCA-370 | P.2 |
| SO₂ | APSA-370 | P.3 |
| H₂S | APSA-370/CU-1 | P.3 |
| NO_x | APNA-370 | P.4 |
| NH₃ | APNA-370/CU-2 | P.4 |
| O₃ | APOA-370 | P.5 |
| THC | APHA-370 | P.6 |
| | APDA-371 | P.7 |
| PM | APDA-375A | P.7 |
| | APDA-372 | P.7 |
| PM Element | PX-375 | P.8 |

Peripheral Equipment for QA/QC

| | |
|----------------------------|------|
| Ozone Gas Generator | |
| OZGU-370SE | P. 5 |
| Hydrogen Generator | |
| OPGU series | P. 6 |
| Multi Gas Generator | |
| APMC-370 | P.10 |
| SGGU-610/640 | P.10 |
| Zero Gas Calibrator | |
| ZNV-7 | P.10 |

Data management

| | |
|---|------|
| Data Logger | |
| (IOX-370: I/O Expander) | P.10 |
| Data management and Reporting Software | |
| (ECO Web) | P. 9 |

Ambient CO Monitor

APMA-370

CE TÜV (EU) FCC U.S. EPA Japan China Korea
 MCERTS (UK) GOST (Russia)



Measurement component

CO

Features

- Cross-flow non-dispersive infrared detector; Low range: 0-5 ppm F.S.
- AS type (anti-shock) interference-compensating detector and purifier for reference gas.
- Reference gas purifier oxidizes CO to CO₂ to eliminate interferences.
- Optics remain free of foreign matter with elimination of reflecting mirrors.

Principle

Cross-flow modulation non-dispersive infrared (NDIR) absorption technology

Conventional technology uses an optical chopper to obtain modulation signals. Instead, the APMA-370 uses solenoid valve cross flow modulation. Fixed amounts of the sample gas and the reference gas are injected alternately into the measurement cell. With the cross flow modulation method, if the same gas is used for both the sample gas and the reference gas (e.g., zero gas could be used for both), no modulation signal will be generated. This has the great advantage that, in principle, when analyzing minute amounts of gas there is no generation of zero-drift. An additional advantage is that the elimination of rotary sectors precludes the need for optical adjustment. These features assure greatly improved stability over long periods of measurement. A further improvement is that in the front chamber of the detector, the measurable components, including interference components, are detected; in the rear chamber, only interference components are detected. By means of subtraction processing, the actual signal obtained is one that has very little interference.

Specifications

- Principle:** Cross flow modulation, non-dispersive infrared (NDIR) absorption technology
Application: CO in ambient air
Range: Standard range: 0-10/20/50/100 ppm, 0-5/10/20/50 ppm
 Optional range: 5 ranges selectable from 0-100 ppm range within 10 times range.
Range selection: Auto or manually ranges selectable. Can be switched by remote operation.
Lower detectable limit: 0.02 ppm (3 σ)
Repeatability: $\pm 1.0\%$ of F.S.
Linearity: $\pm 1.0\%$ of F.S.
Zero drift: <LDL/day at lowest range <0.2 ppm/week at lowest range
Span drift: <LDL/day at lowest range $\pm 1.0\%$ F.S./week
Response time (T₉₀): Within 50 sec at lowest range
Sample gas flow rate: Approx. 1.5 L/min
Calibration gas: Span: CO, Zero: Zero gas
Indication: Measured value, range, alarm, maintenance screen
Alarms: During AIC, zero calibration error, span calibration error, temperature error in catalyzer, etc.
On-screen messages are available in four languages: English, German, French, and Japanese.
Input/output: • 0-1 V/0-10 V/4-20 mA, to be specified (2 systems: either (1) momentary value and integrated or (2) moving average value) • Contact input/output • RS-232C (option)
Ambient temperature: 5-40°C
Power: 100/110/115/120/220/230/240 VAC, 50/60 Hz (to be specified)
Dimensions: 430(W)x550(D)x221(H) mm
Mass: Approx. 16 kg

Flow sheet (Example)

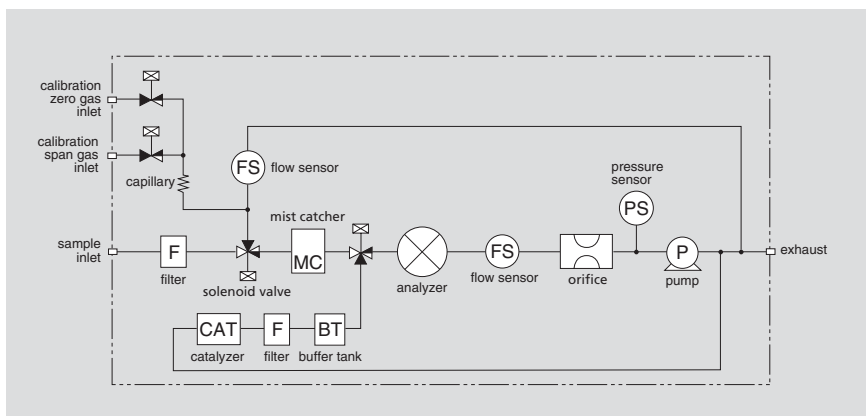

Ambient CO₂ Monitor

APCA-370

CO₂

Measurement component :

- Principle:** Cross-flow modulation, infrared (NDIR) absorption technology
Specification:
Range: 0 ppm to 500/1000 ppm
Lower detectable limit: 0.5 ppm (2 σ)
Repeatability: $\pm 1.0\%$ of F.S.
Linearity: $\pm 2.0\%$ of F.S.
Zero drift: ± 1.0 ppm/day
 ± 2.0 ppm/week
 (ambient temperature change: within 5°C)
Span drift: $\pm 2.0\%$ of F.S./day
 $\pm 3.0\%$ of F.S./week
 (ambient temperature change: within 5°C)
Response time (T₉₀): 60 sec or shorter
Sample gas flow rate: Approx. 0.7 L/min
Indication: Measured value, alarm, time, alarm history, calibration history, etc.
Alarms: Zero calibration, Span calibration, etc.

Ambient SO₂ Monitor

APSA-370

CE TÜV (EU) FCC U.S. EPA China Korea
 MCERTS (UK) GOST (Russia)



Measurement component



Features

- UV-fluorescent detector resistant to moisture interference; Low range: 0-0.05 ppm F.S.
- Alternately to FDP measurements, the detector design is highly SO₂ selective and requires no supplemental gas.
- Integral HC-cutter with a selective membrane eliminates interfering components.
- Incorporates a lamp intensity compensator.
- Uses a built-in inert PTFE sample inlet filter.

Principle

UV fluorescence

The UV fluorescence method operates on the principle that when the SO₂ molecules contained in the sample gas are excited by ultraviolet radiation they emit a characteristic fluorescence in the range of 220-420 nm. This fluorescence is measured and the SO₂ concentration is obtained from changes in the intensity of the fluorescence.

The reactive mechanism is

- (1) SO₂+hv₁→SO₂* (2) SO₂*→SO₂+hv₂
 (3) SO₂*→SO+(O) (4) SO₂*+M→SO₂+M

Here, (1) shows the excited state of the SO₂ molecules that have absorbed the amount of energy hv₁ by ultraviolet radiation. (2) shows the amount of energy, hv₂ emitted by the excited molecules as they return to the ground state. (3) shows the decomposition by the light emitted from the excited molecules. (4) shows the quenching, i.e., the energy lost by the excited molecules colliding with other molecules. The APSA-370 uses an Xe lamp as the light source, and the fluorescent chamber design minimizes scattered light. The optical system has been carefully designed with low background light, making it possible to take measurements with a highly stable zero point. In addition, a reference detector monitors any fluctuation in the intensity of the light source. This allows the unit to calibrate itself automatically for sensitivity, resulting in greater span stability.

Specifications

Principle: UV fluorescence (UVF)

Application: SO₂ in ambient air

Range: Standard range: 0-0.05/0.1/0.2/0.5 ppm

Optional range: 5 ranges selectable from 0-10 ppm range within 10 times range.

Range selection: Auto or manually ranges selectable. Can be switched by remote operation.

Lower detectable limit: 0.5 ppb (3σ)

Repeatability: ±1.0% of F.S.

Linearity: ±1.0% of F.S.

Zero drift: <LDL/day at lowest range <LDL/week at lowest range

Span drift: <LDL/day at lowest range <LDL/week at lowest range

Response time (T₉₀): Within 120 sec at lowest range

Sample gas flow rate: Approx. 0.7 L/min

Calibration gas: Span: SO₂, Zero: Purified Air

Indication: Measured value, range, alarm, maintenance screen

Alarms: During AIC, zero calibration error, span calibration error, temperature error in catalyzer, etc.

On-screen messages are available in four languages: English, German, French, and Japanese

Input/output: • 0-1 V/0-10 V/4-20 mA, to be specified (2 systems: either (1) momentary value and integrated or (2) moving average value) • Contact input/output • RS-232C (option)

Ambient temperature: 5-40°C

Power: 100/110/115/120/220/230/240 VAC, 50/60 Hz (to be specified)

Dimensions: 430(W)×550(D)×221(H) mm

Mass: Approx. 19 kg

Flow sheet (Example)

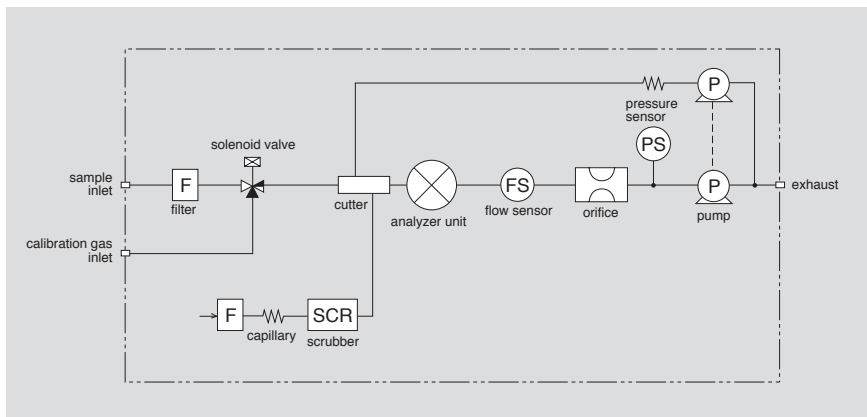

Ambient Hydrogen sulfide (H₂S) Monitor

APSA-370/CU-1

Measurement component:



Principle: Oxidation catalyst + Ultra Violet Fluorescence

Model: Converter Unit: CU-1
 Ambient SO₂ Monitor: APSA-370

Range: 0-0.1/0.2/0.5/1.0 ppm (Standard)
 0-0.05/0.1/0.2/0.5 ppm (High sensitivity)

Power: 100/110/115/120/220/230/240 VAC, 50/60 Hz

Dimension: CU-1: 430(W) × 550(D) × 221(H) mm
 APSA-370: 430(W) × 550(D) × 221(H) mm

Mass: CU-1: Approx. 10 kg
 APSA-370: Approx. 19 kg

Ambient NO_x Monitor

APNA-370

CE TÜV (EU) FCC U.S. EPA China Korea
 MCERTS (UK) GOST (Russia)



Measurement component NO_x

Features

- Continuous NO_x, NO, NO₂ measurements using a dual cross-flow single chemiluminescence detector and referential calculation.
- HORIBA original detector (Silicon photodiode sensor) respond to gas concentration quickly.
- Stable, repeatable measurements; Low range: 0-0.1 ppm F.S.
- Includes auto-recycle internal drier to make dry air for generating ozone gas
- Base configuration includes: O₃ drier unit, O₃ decomposer, reference gas generator and sample pump.

Principle

Cross flow modulation type, reduced pressure chemiluminescence (CLD)

The chemiluminescence method uses the reaction of NO with O₃

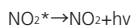
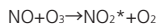

A portion of the NO₂ generated as the result of this reaction becomes NO₂*. As these excited molecules return to the ground state, chemiluminescence is generated in the range of 600 nm to 3,000 nm. The light intensity is in proportion to the concentration of NO molecules and by measuring it we obtain the NO concentration of the sample. A deoxidation converter changes the NO₂ to NO, which is measured. In other words, the NO₂ concentration can be obtained by the difference between (1) the NO_x concentration measured when the sample gas is directed through a converter and (2) the NO concentration measured when the gas is not run through the converter.

Specifications

Principle: Cross flow modulation type, reduced pressure chemiluminescence (CLD)

Application: NO₂, NO and NO_x in ambient air

Range: Standard range: 0-0.1/0.2/0.5/1.0 ppm

Optional range: 5 ranges selectable from 0-10 ppm range within 10 times range.

Range selection: Auto or manually ranges selectable. Can be switched by remote operation.

Lower detectable limit: 0.5 ppb (3σ)

Repeatability: ±1.0% of F.S.

Linearity: ±1.0% of F.S.

Zero drift: <LDL/day, at lowest range ±1.0 ppb/week at lowest range

Span drift: <LDL/day at lowest range ±1.5% of F.S./week

Response time (T₉₀): Within 90 sec at lowest range

Sample gas flow rate: Approx. 0.8 L/min

Calibration gas: Span: NO, Zero: Purified Air

Indication: Measured value, range, alarm, maintenance screen

Alarms: During AIC, zero calibration error, span calibration error, temperature error in converter, etc.

On-screen messages are available in four languages: English, German, French, and Japanese

Input/output: • 0-1 V/0-10 V/4-20 mA, to be specified (2 systems: either (1) momentary value and integrated or (2) moving average value) • Contact input/output • RS-232C (option)

Ambient temperature: 5-40°C

Power: 100/110/115/120/220/230/240 VAC, 50/60 Hz (to be specified)

Dimensions: 430(W)x550(D)x221(H) mm

Mass: Approx. 21 kg

Flow sheet (Example)

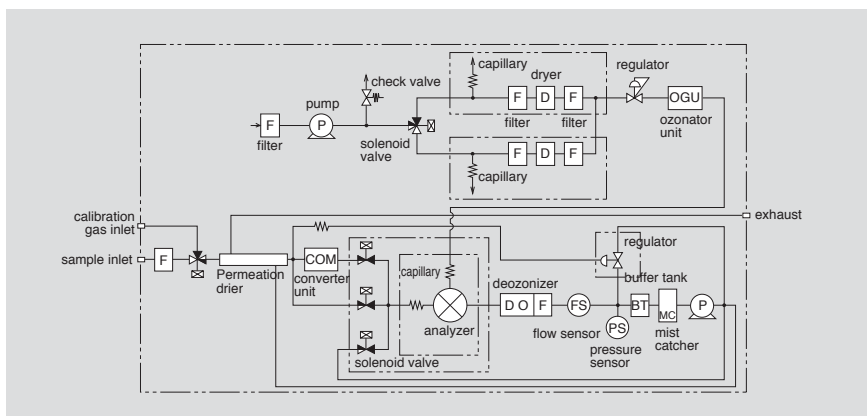

Ambient Ammonium (NH₃) Monitor

APNA-370/CU-2

Measurement component:

NH₃



Principle: Oxidation catalyst + Chemiluminescence

Model: Converter Unit: CU-2
 Ambient NO_x Monitor: APNA-370

Range: 0-1.0/2.0/5.0/10 ppm (Standard)
 0-0.1/0.2/0.5/1.0 ppm (High sensitivity)

Power: 100/110/115/120/220/230/240 VAC, 50/60 Hz

Dimension: APNA-370: 430(W) x 550(D) x 221(H) mm
 CU-2: 430(W) x 450(D) x 310(H) mm

Mass: APNA-370: approx. 21 kg
 CU-2: approx. 20 kg

Ambient O₃ Monitor

APOA-370

CE TÜV (EU) FCC U.S. EPA China Korea

MCERTS (UK) GOST (Russia)



Measurement component

O₃

Features

- Cross-flow modulated ultra-violet absorption detector; Low range: 0-0.1 ppm F.S.
- Heated de-ozonator removes any O₃ in the reference gas to:
 - Reduce interference
 - Eliminate moisture interference
 - Prolong life-cycle of the UV lamp
- Only inert materials (glass or PTFE) contact sample.

Principle

Cross-flow modulation type,
Non dispersive ultra-violet absorption
method (NDUV)

The ultra-violet absorption method works on the principle that ozone absorbs ultra-violet rays in the area of 254 nm. Measurements are taken from continuous, alternate injections of the sample gas and the reference gas into the measurement cell, controlled by a long-life solenoid valve. The cross flow modulation method is characteristically zero-drift free. A comparative calculation circuit automatically compensates for all fluctuations in the mercury vapor light source and in the detector. This means that, in principle, the APOA-370 makes it possible to carry out zero-span drift free, continuous measurements. In addition, HORIBA's unique de-ozonator for the comparison gas line is unaffected by interference elements or moisture retention, prolonged, stable measurement is possible.

Specifications

Principle: Cross flow modulation type, Ultra-violet-absorption method (NDUV)

Application: O₃ in ambient air

Range: Standard range: 0-0.1/0.2/0.5/1.0 ppm

Optional range: 5 ranges selectable from 0-10 ppm range within 10 times range.

Range selection: Auto or manually ranges selectable. Can be switched by remote operation.

Lower detectable limit: 0.5 ppb (3σ)

Repeatability: ±1.0% of F.S.

Linearity: ±1.0% of F.S.

Zero drift: <LDL/day at lowest range <LDL/week at lowest range

Span drift: <LDL/day at lowest range <LDL/week at lowest range

Response time (T₉₀): Within 75 sec at lowest range

Sample gas flow rate: Approx. 0.7 L/min

Calibration gas: Span: O₃, Zero: Purified Air

Indication: Measured value, range, alarm, maintenance screen

Alarms: During AIC, zero calibration error, span calibration error, temperature error in ozone separator, light intensity error, etc.

On-screen messages are available in four languages: English, German, French, and Japanese.

Input/output: • 0-1 V/0-10 V/4-20 mA, to be specified (2 systems: either (1) momentary value and integrated or (2) moving average value) • Contact input/output • RS-232C (option)

Ambient temperature: 5-40°C

Power: 100/110/115/120/220/230/240 VAC, 50/60 Hz (to be specified)

Dimensions: 430(W)×550(D)×221(H) mm

Mass: Approx. 15 kg

Flow sheet (Example)

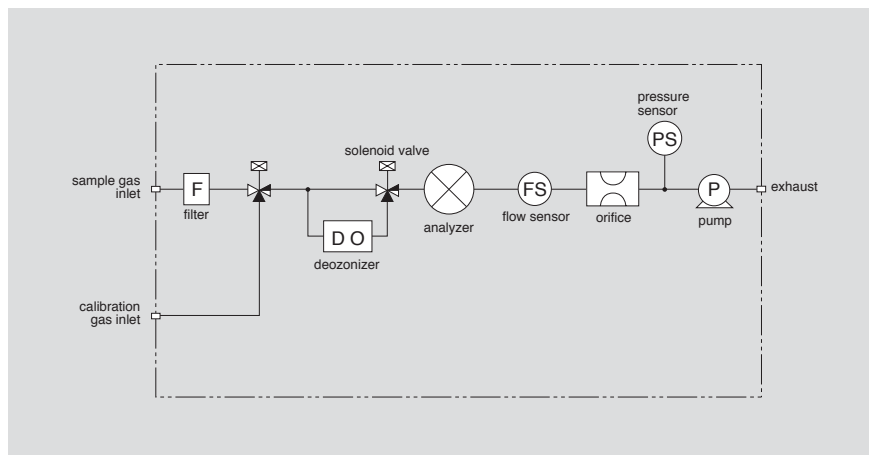

Ozone Gas Generator

OZGU-370SE

Calibration Unit for APOA-370



Ambient THC Monitor

APHA-370

CE FCC China Korea GOST (Russia)



Measurement component



Features

- Flame ionization detector with selective combustion simultaneously measures THC, NMHC, and CH₄.
- Single detector eliminates zero drift; Low range: 0-5 ppmC F.S.
- Integrates relative sensitivity correction for CH₄ and NMHC.
- Integrates a reference and combustion air generator, NMHC cutter and sample pump.
- Requires H₂ as fuel gas for the FID.

Principle

Flame ionization detection method (FID) with selective-combustion

The flame ionization detection method (FID) — used in combination with the selective-combustion system — utilizes the ionization that occurs as the result of the high-temperature energy from combustion at the tip of the burner jet when organic carbon compounds are introduced into the hydrogen flame. The hydrogen flame is located between two electrodes. When an electrical voltage is applied across these electrodes a minute ion current proportional to the hydrocarbon concentration is produced. This current is monitored by a low leakage amplifier, giving a voltage readout for THC. To measure CH₄ the sample gas is passed through the selective catalytic combustion unit (the NMHC cutter), which oxidizes NMHC without oxidizing CH₄. This is shown as *A* below. *B* represents the THC concentration measured without passing the gas through the NMHC cutter. Thus *B - A* will give the concentration of NMHC. The final concentration value is calculated using a relative-sensitivity correction coefficient, *k*, as shown below.

CH₄ Concentration *A*
 NMHC Concentration *k(B - A)*
 THC Concentration *A + k(B - A)*

Specifications

Principle: Flame ionization detection (FID) with selective combustion

Application: THC, NMHC, and CH₄ in ambient air

Range: Standard range: 0-5/10/20/50 ppmC

Optional range: 5 ranges selectable from 0-100 ppmC range within 10 times range.

Range selection: Auto or manually ranges selectable. Can be switched by remote operation.

Lower detectable limit: 0.022 ppmC (3σ)

Repeatability: ±1.0% of F.S.

Linearity: ±1.0% of F.S.

Zero drift: <LDL/day at lowest range ±0.05 ppmC/week at lowest range

Span drift: <LDL/day at lowest range ±0.5% F.S./week

Response time (T₉₀): Within 60 sec at lowest range

Sample gas flow rate: Approx. 0.9 L/min

Calibration gas: Span: CH₄, Zero: Purified Air

Indication: Measured value, range, alarm, maintenance screen

Alarms: During AIC, zero calibration error, span calibration error, temperature error in zero gas purifier, ignition failure error, etc.

On-screen messages are available in four languages: English, German, French, and Japanese.

Input/output: • 0-1 V/0-10 V/4-20 mA, to be specified (2 systems: either (1) momentary value and integrated or (2) moving average value) • Contact input/output • RS-232C (option)

Ambient temperature: 5-40°C

Power: 100/110/115/120/220/230/240 VAC, 50/60 Hz (to be specified)

Dimensions: 430(W)×550(D)×221(H) mm

Mass: Approx. 33 kg

Notes: ppmC is shown as symbol, not as unit.

Flow sheet (Example)

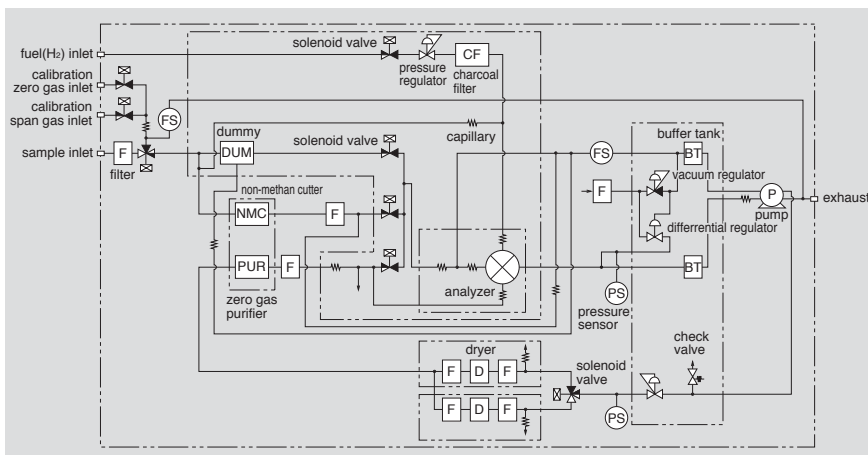

Beta-Ray Attenuation type Dust Analyzer

APDA-371

CE TÜV (EU) U.S. EPA

> Measurement component

PM

> Principle

Beta-ray attenuation



> Features

- Long term unattended remote operation of up to 60 days between site visits
- Hourly filter advances minimize effects of volatile compounds
- Integrated data logger allows the connection of up to six additional

> Specifications

Principle: Beta Ray attenuation

Application: PM2.5, PM10, TSP

Standard Range: 0-1.000 mg/m³ (0-1000 µg/m³)

Optional Ranges : 0-0.100, 0.200, 0.250, 0.500, 2.000, 5.000, 10.000 mg/m³
(special applications)

Repeatability: ±2.0% of F.S. at 1000/5000/10000 µg/m³ range

Linearity: ±3.0% of F.S. at 1000/5000/10000 µg/m³ range

Zero drift: ±20 µg/m³/day at 200/500/1000/5000/10000 µg/m³

Span drift: ±30 µg/m³/day at 200/500 µg/m³ range

±3.0% of F.S. at 1000/5000/10000 µg/m³ range

Sample gas flow rate: Approx. 16.7 L/min

Alarms: Tape failure, Flow rate failure, etc.

Input/output: 0-1 V, pulse signal, Contact Input/Output(Range, Power failure, alarm, etc.)
Option: RS-232C, LAN connecting terminal(TCP/IP)

Operating temperature: 0-50°C

Power: 100-230 VAC, 50/60 Hz

Dimensions: 430(W)×400(D)×310(H) mm

Mass: Approx. 24.5 kg without external accessories

Ambient Particulate Monitor

APDA-375A

China

Measurement component :

PM

Principle: Beta-ray attenuation

Application: PM2.5, PM10, TSP



*Please contact to HORIBA for the detail

Light Scattering type Dust Analyzer

APDA-372

CE TÜV (EU)

> Measurement component

PM

> Principle

Optical light scattering



> Features

- Continuous real-time measurement of PM values simultaneously with additional information through particle number concentration
- Time resolution adjustable from 1sec up to 24hr
- LED light source with high stability, long lifetime and durability

> Specifications

Principle: Optical light scattering

Application: PM1, PM2.5, PM10, TSP

Range(Particle size): PMtot (0.18-18 µm)

Range(Number): 0-20,000 particle/cm³

Range(Mass): 0-1,500 µg/m³

Time resolution: 1s-24h (or on demand)

Flow rate: 5.0 L/min

Working temperature: 0-35°C

Power: 115-230 VAC, 50-60 Hz

Power consumption: 140 W

Dimensions: 450(W)×320(D)×190 or 185(H) mm

Mass: Approx. 9.3 kg

Interface: Touch display 800×480 pixels

Data logger (Inclusive): 4 GB Compact Flash

External connection: LAN, WiFi, RS-232/485, USB,
Optional external GRPS/UMTS modem

Continuous Particulate Monitor with X-ray Fluorescence

PX-375

CE FCC

Measurement component



Features

- Continuous monitor of PM mass and the elemental concentration by a single unit directly in the field
- Advanced analysis method by world proven technologies
- HORIBA's newly developed filter tape provides excellent sensitivity and precise performance

Specifications

Common

Measured object: Particulate matter (PM10, PM2.5, PM1, TSP)
Measurement content: Particulate mass concentration and element concentration
Flow rate: 16.7 L/min
Ambient operation temperature: 10°C~30°C
Relative humidity: 0~80% RH noncondensing
Power supply: 100-240 VAC ±10% (up to 250 V), 50/60 Hz ±1 Hz
Power consumption: Approx. 400 VA
External dimension: 430(W)×560(D)×285(H) mm (without sampling pipe and measurement head)
Mass: Approx. 49 kg
Data output: CSV file (Average PM mass and elemental concentration)
External connection: Ethernet™, USB

Mass unit

Measurement method: Beta-ray attenuation
PM10: US EPA Louvered PM10 Inlet
PM2.5: VSCC™ Cyclone
PM1: SSC™ Cyclone
TSP: TSP Inlet
Measurement range: 0~200/500/1000 µg/m³
Repeatability: ±2% (against reference foil value)
Span drift: ±3% (24 hours)
Lowest detection limit (2σ): ±4 µg/m³ (24 hours)
Sampling and measurement cycle: 0.5/1/2/3/4/6/8/12/24 hours

Element unit

Measurement method: Energy dispersive X-ray spectroscopy
Detectable elements: Standard parameter is Al, Si, S, Ti, Cr, Mn, Ni, Cu, Zn, Pb, K, Ca, V, Fe, As. See Table 2 "Detectable Elements"
Detector: SDD (Silicon Drift Detector)
Sample image: CMOS camera
Lowest detection limit (2σ): Recommended EPA Method IO 3.3 See Table 1 "Lowest Detection Limit (Example)"
Analysis time: 500s as standard 100/200/500/1000/2000/5000/10000s selectable
Calibration material for X-ray intensity for standard parameter: NIST SRM 2783, other materials (option)
Safety functions for X-ray: Internal lock system, Key switch, X-ray indication light

Principle

Mass unit:
Beta-ray attenuation

Element unit:
Energy dispersive X-ray spectroscopy



Lowest Detection Limit (Example) (2σ) (ng/m³) (Table 1)

| Element | Analysis time (sec.) | | |
|---------|----------------------|------|-------|
| | 100 | 1000 | 10000 |
| Ti | 26.5 | 8.4 | 2.6 |
| Cr | 4.5 | 1.4 | 0.4 |
| Mn | 5.8 | 1.8 | 0.6 |
| Cu | 5.7 | 1.8 | 0.6 |
| Zn | 3.0 | 1.0 | 0.3 |
| Se | 3.4 | 1.1 | 0.3 |
| Ag | 15.8 | 5.0 | 1.6 |
| Cd | 35.9 | 11.3 | 3.6 |
| Sn | 38.4 | 12.2 | 3.8 |
| Hg | 7.7 | 2.4 | 0.8 |
| Pb | 5.3 | 1.7 | 0.5 |

* LDL (σ) is half of the LDL (2σ)

Detectable Elements (Table 2)

| Detectable Elements | | | | | | | | | | | | | | | | | | | | | | |
|---------------------|----|------------|----|----|----|----|----|----|----|----|----|-----|----|-----|----|-----|-----|----|---|---|----|----|
| H | | | | | | | | | | | | | | | | | | He | | | | |
| Li | Be | | | | | | | | | | | | | | | | B | C | N | O | F | Ne |
| Na | Mg | | | | | | | | | | | | | | | | Al | Si | P | S | Cl | Ar |
| K | Ca | Sc | Ti | V | Cr | Mn | Fe | Co | Ni | Cu | Zn | Ga | Ge | As | Se | Br | Kr | | | | | |
| Rb | Sr | Y | Zr | Nb | Mo | Tc | Ru | Rh | Pd | Ag | Cd | In | Sn | Sb | Te | I | Xe | | | | | |
| Cs | Ba | | Hf | Ta | W | Re | Os | Ir | Pt | Au | Hg | Tl | Pb | Bi | Po | At | Rn | | | | | |
| Fr | Ra | | Rf | Ha | Sg | Bh | Hs | Mt | Ds | Rg | Cn | Unt | Fl | Unp | Lv | Uus | Uno | | | | | |
| | | lanthanoid | | | | | | | | | | | | | | | | | | | | |
| | | La | Ce | Pr | Nd | Pm | Sm | Eu | Gd | Tb | Dy | Ho | Er | Tm | Yb | Lu | | | | | | |
| | | actinoid | | | | | | | | | | | | | | | | | | | | |
| | | Ac | Th | Pa | U | Np | Pu | Am | Cm | Bk | Cf | Es | Fm | Md | No | Lr | | | | | | |

* Standard parameters, calibrated by standard calibration materials.
 * For measurement of element concentration calibration by standard calibration materials is needed.
 * Please contact separately about elements, marked as non-detectable.

Sampling Filter

HORIBA's newly developed filter tape provides excellent sensitivity and precise performance

- Feature:**
- 2 layer non-woven PTFE fabric filter construction prevents passing of PM onto the reverse side.
 - Due to the extremely low-impurity concentration, the filter enables ultra low concentration analysis.
 - Chemical background of the filter tape is extremely low. Therefore the filter with collected sample could be used for chemical analysis by other scientific analytical instruments. (ICP-MS etc.)

Patents:

- USA Patent No. 8012231
- JAPAN Patent No. 4590367 No. 4387164
- CHINA Patent No. ZL200410032415.3
- GERMAN Patent No. 102004018260



TFH-08



TFH-47L

AQMS Air Quality Monitoring System

The Air Quality Monitoring System (AQMS) is a facility to measure wind speed, direction, other weather parameters, concentration of air pollutants (such as SO₂, NO_x, CO, O₃, THC etc), and particulate matters continuously all year round. Mobile AQMS can also be customized to monitor multiple sites via one system.

Fixed Station

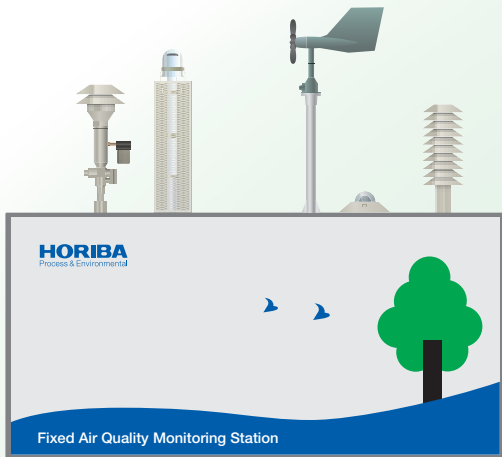

Mobile Station

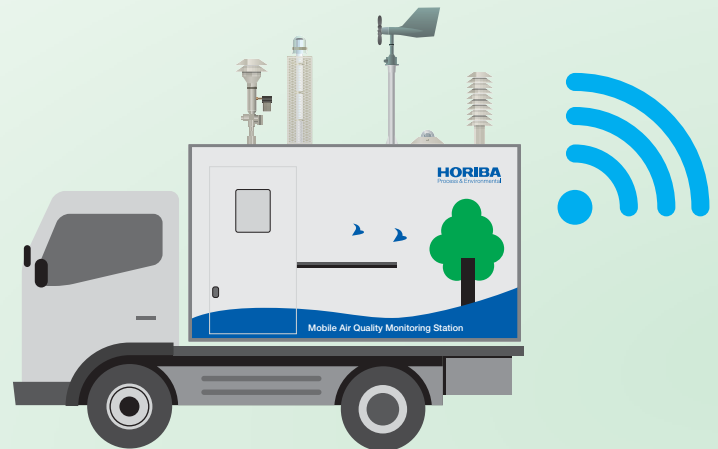

Mini Station



Data Management and Reporting Software

ECO Web

- Collect data from Ambient Air Monitoring Stations
- Manage and store collected data
- Provide reports based on stored data

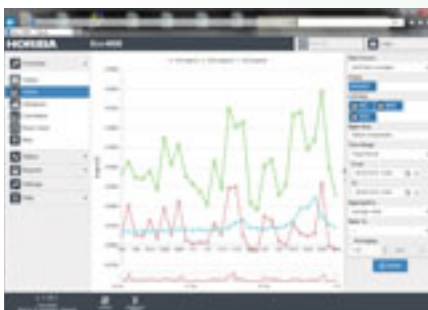

**Inside of AQMS
(Examples)**



Inside of the AQMS

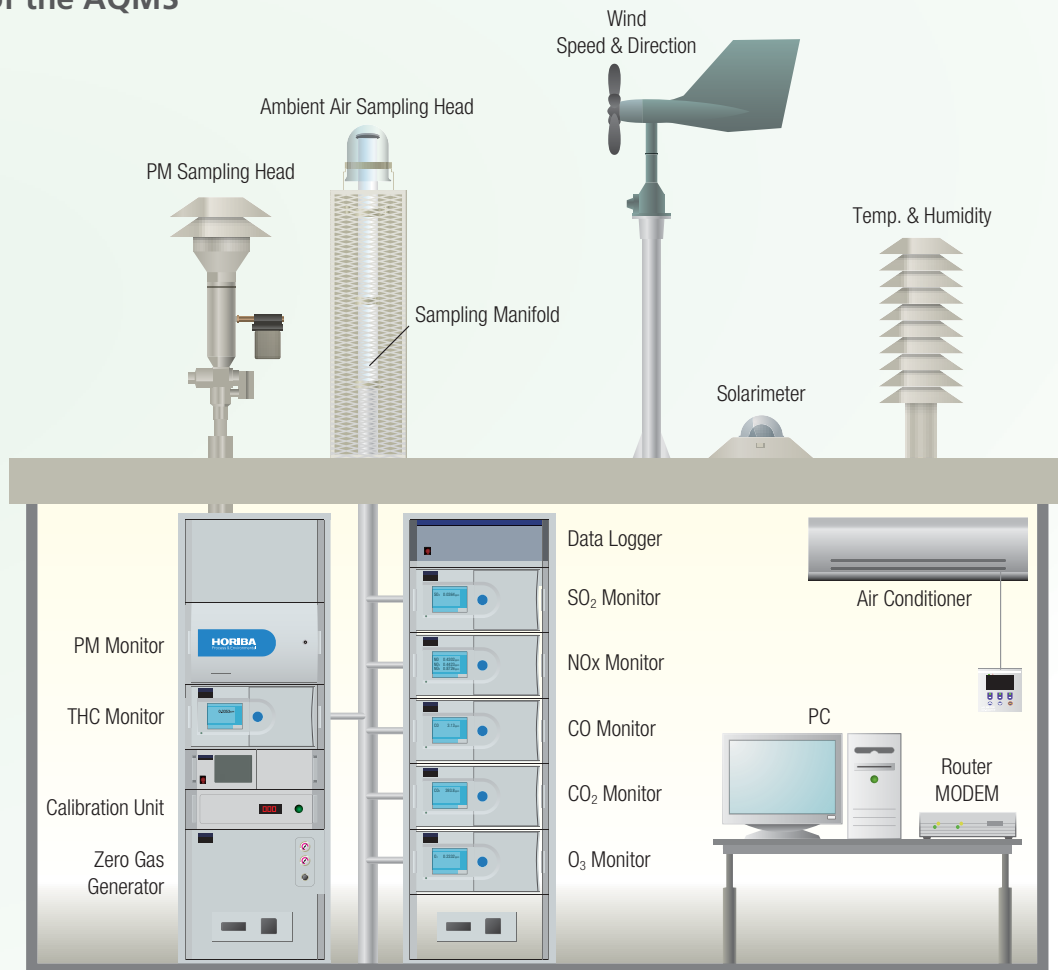

Multi Gas Calibrator

APMC-370

NO, SO₂, CO, CO₂, O₃, H₂S, NH₃
(Other parameters are also available)



SGGU-610/640

NO, SO₂, Zero gas



Zero Gas Generator

ZNV-7

Zero gas



Data Logger

IOX-370: I/O Expander

Collection, average calculation,
storage and transfer to a central
location of environmental data



*HORIBA provides local solutions for air quality monitoring such as data management software and calibrator etc. Please contact to HORIBA for the detail.

➤ Standard 19-inch Packages

Each HORIBA AP-370 Series Monitor is packaged in a light metal enclosure with sliding chassis suitable for either a table-top set-up in a research laboratory or mounting on a standard 19-inch rack for permanent installation. All the controls and serviceable components are accessible from the front for easy maintenance while the plumbing and cable connections are neatly arranged at the back.

Dimensional Outline Unit: mm

APMA-370 / APSA-370 / APNA-370 / APHA-370 / APOA-370

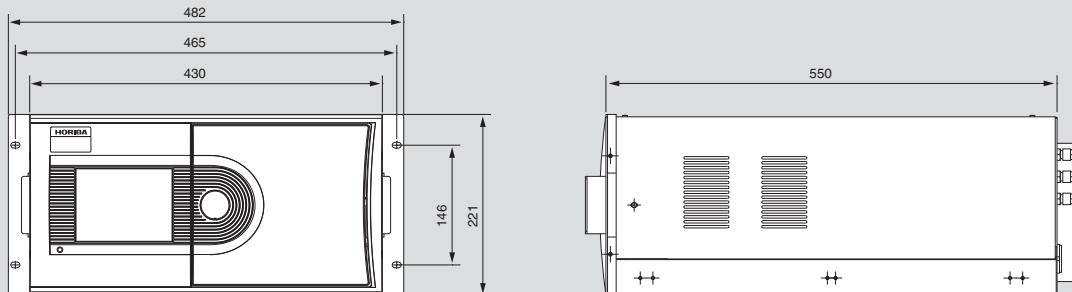

These icons represent following measurement act in each country.

Measurement Act in Japan

PATTERN APPROVAL CERTIFICATE OF THE MEASURING INSTRUMENTS OF THE PEOPLE'S REPUBLIC OF CHINA

Type Approval Certificate of Environmental Instrument

*The specifications described in this catalog depend on usage environment.



The HORIBA Group adopts IMS (Integrated Management System) which integrates Quality Management System ISO9001, Environmental Management System ISO14001, and Occupational Health and Safety Management System OHSAS18001. We have now integrated Business Continuity Management System ISO22301 in order to provide our products and services in a stable manner, even in emergencies.



Please read the operation manual before using this product to assure safe and proper handling of the product.

- The specifications, appearance or other aspects of products in this catalog are subject to change without notice.
- Please contact us with enquiries concerning further details on the products in this catalog.
- The color of the actual products may differ from the color pictured in this catalog due to printing limitations.
- It is strictly forbidden to copy the content of this catalog in part or in full.
- The screen displays shown on products in this catalog have been inserted into the photographs through compositing.
- All brand names, product names and service names in this catalog are trademarks or registered trademarks of their respective companies.

<http://www.horiba.com>

HORIBA, Ltd. **Japan**

Head Office
2 Miyano Higashi-cho, Kisshoin, Minami-ku, Kyoto, Japan
Phone: 81 (75) 313-8121 Fax: 81 (75) 321-5725

HORIBA (China) Trading Co., Ltd. **China**

Unit D, 1F, Building A, Synnex International Park, 1068 West Tianshan Road, Shanghai, 200335, China
Phone: 86 (21) 6289-6060 Fax: 86 (21) 6289-5553

Beijing Branch

12F, Metropolis Tower, No.2, Haidian Dong 3 Street, Beijing, 100080, China

Phone: 86 (10) 8567-9966 Fax: 86 (10) 8567-9066

Guangzhou Branch

Rm 1612, Golden Digital Network Center, 138 East Tiyy Road, Guangzhou, 510620, China

Phone: 86 (20) 3878-1883 Fax: 86 (20) 3878-1810

HORIBA Taiwan, Inc. **Taiwan**

8F.-8, No.38, Taiyuan St. Zhubei City, Hsinchu County 30265, Taiwan (R.O.C.)

Phone: 886 (3) 560-0606 Fax: 886 (3) 560-0550

HORIBA KOREA Ltd. **Korea**

25, 94-Gil, Ilijk-Ro, Manan-Gu, Anyang-Si, Gyeonggi-Do, 13901, Korea

Phone: 82 (31) 296-7911 Fax: 82 (31) 296-7913

HORIBA Instruments (Singapore) Pte Ltd. **Singapore**

3 Changi Business Park Vista #01-01 Akzonobel House, Singapore 486051

Phone: 65 (6) 745-8300 Fax: 65 (6) 745-8155

HORIBA Vietnam Co., Ltd. **Vietnam**

Unit 3, 16 Floor, Detech Tower II, 107 Nguyen Phong Sac Street, Dich Vong Hau Ward, Cau Giay District, Hanoi, Vietnam

Phone: 84 (24) 3795-8552 Fax: 84 (24) 3795-8553

HORIBA (Thailand) Limited **Thailand**

East Office

850 / 7 Soi Lat Krabang 30 / 5, Lat Krabang Road, Lat Krabang, Bangkok 10520, Thailand

Phone: 66 (0) 2734 4434 Fax: 66 (0) 2734 4438

PT HORIBA Indonesia **Indonesia**

Jl. Jalur Sutera Blok 20A, No.16-17, Kel. Kunciran, Kec. Pinang Tangerang-15144, Indonesia

Phone: 62 (21) 3044-8525 Fax: 62 (21) 3044-8521

HORIBA India Private Limited **India**

246, Okhla Industrial Estate, Phase 3 New Delhi-110020, India
Phone: 91 (11) 4646-5000 Fax: 91 (11) 4646-5020

Technical Center

D-255, Chakan MIDC Phase-II, Bhamboli Village, Pune-410501, India
Phone: 91 (21) 3567-6000

Bangalore Office

No.55, 12th Main, Behind BDA Complex, 6th sector, HSR Layout, Bangalore South, Bangalore-560102, India
Phone: 91 (80) 4127-3637

HORIBA Instruments Incorporated **USA**

9755 Research Drive, Irvine, CA 92618, U.S.A.
Phone: 1 (949) 250-4811 Fax: 1 (949) 250-0924

Houston Office

5390 Bay Oaks Drive, Pasadena, TX 77505
Phone: 1 (281) 482-4334 Fax: 1 (281) 674-6058

HORIBA Instruments Brasil, Ltda. **Brasil**

Rua Presbitero Plinio Alves de Souza, 645, Parte A, Loteamento Multivias, Jardim Ermidia II - Jundiai Sao Paulo - CEP 13.212-181 Brazil

Phone: 55 (11) 2923-5400 Fax: 55 (11) 2923-5490

HORIBA UK Limited **UK**

Kyoto Close Moulton Park, Northampton NN3 6FL, UK
Phone: 44 (1604) 542-500 Fax: 44 (1604) 542-699

HORIBA Europe GmbH **Germany**

Hans-Mess-Str.6 D-61440 Oberursel Germany
Phone: 49 (6172) 1396-0 Fax: 49 (6172) 1373-85

Leichlingen Office

Julius-kronenberg Str.9 D-42799 Leichlingen Germany
Phone: 49 (2175) 8978-0 Fax: 49 (2175) 8978-50

HORIBA Europe Research Center **France**

Avenue de la Vauve - Passage Jobin Yvon CS 45002 - 91120 Palaiseau - France

Phone: 33 (1) 69-74-72-00 Fax: 33 (1) 69-31-32-20

HORIBA Europe GmbH **Sweden**

Sweden Branch (Gothenburg)

Grimboasen 10 A, S-417 49 Gothenburg, Sweden
Phone: (46) 10-161-1500 Fax: (46) 10-161-1503

HORIBA Czech **Czech**

Prague Office

Prumyslova 1306 / 7, CZ-10200, Praha 10, Czech Republic
Phone: 420 (2) 460-392-65

HORIBA (Austria) GmbH **Austria**

Kaplanstrasse 5 A-3430 Tulln, Austria
Phone: 43 (2272) 65225 Fax: 43 (2272) 65230

HORIBA (Austria) GmbH **Romania**

Romania Branch

B-dul.Republicii, nr. 164, Etaj Parter, Birourile nr. 3 si 4 PiteștiJudețul Arges110177 Romania
Phone: 40 (348) 807117 Fax: 40 (348) 807118